

SPECIFICATION

AIR INLET :

1/2" BSPT (FEMALE)

MAXIMUM FLOW :

90 GPM (340.7 LPM)

FLUID INLET/OUTLET :

1.5" BSPT

MAX. OPERATING PRESSURE :

120 PSI (8.3 bar)

SUSPENDED SOLIDS MAX DIA. :

1/4" (6.4mm)

MAX. DRY SUCTION LIFT :

19 FT (5.8m)

WEIGHT :

51.5 lbs (23.4kg) Aluminium

84.5 lbs (38.3kg) Stainless Steel

DIMENSIONAL DATA

Dimensions shown are for reference only, they are displayed in inches and millimeters (mm).

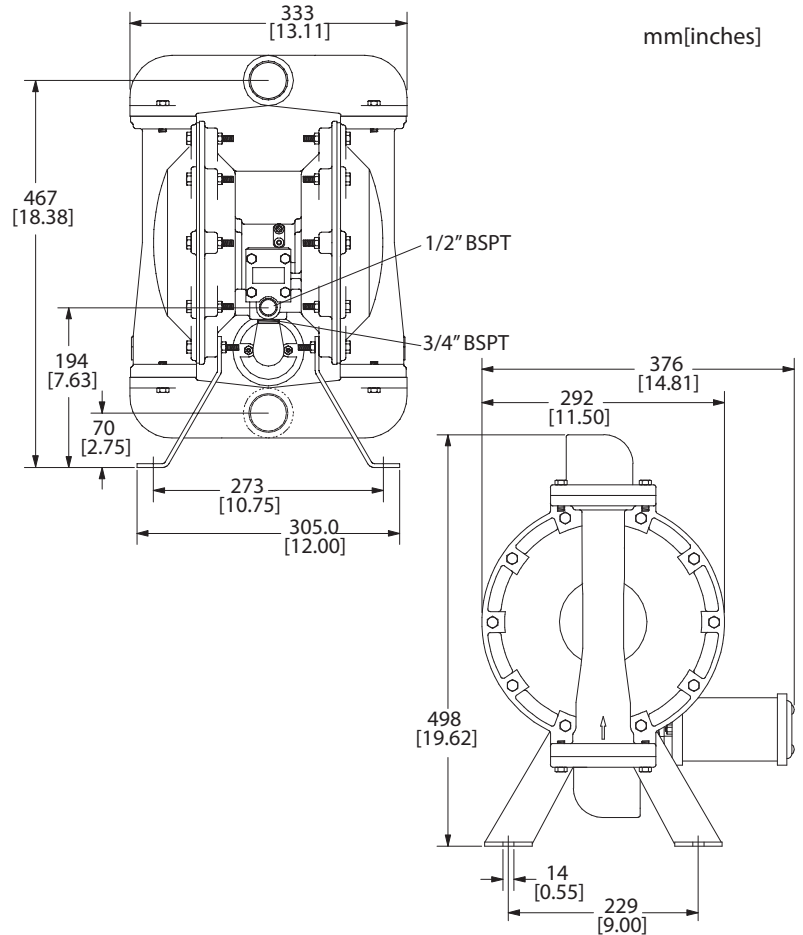

Performance Curve for Water at Ambient Temperature

